

LM2660 Switched Capacitor Voltage Converter

 Check for Samples: [LM2660](#)

FEATURES

- Inverts or Doubles Input Supply Voltage
- Narrow SO-8 and Mini SO-8 Package
- 6.5Ω Typical Output Resistance
- 88% Typical Conversion Efficiency at 100 mA
- Selectable Oscillator Frequency: 10 kHz/80 kHz
- Optional External Oscillator Input

APPLICATIONS

- Laptop Computers
- Cellular Phones
- Medical Instruments
- Operational Amplifier Power Supplies
- Interface Power Supplies
- Handheld Instruments

DESCRIPTION

The LM2660 CMOS charge-pump voltage converter is a versatile unregulated switched capacitor inverter or doubler. Operating from a wide 1.5V to 5.5V supply voltage, the LM2660 uses two low-cost capacitors to provide 100 mA of output current without the cost, size and EMI related to inductor-based converters. With an operating current of only 120 μA and operating efficiency greater than 90% at most loads, the LM2660 provides ideal performance for battery-powered systems. LM2660 devices can be operated directly in parallel to lower output impedance, thus providing more current at a given voltage.

The FC (frequency control) pin selects between a nominal 10 kHz or 80 kHz oscillator frequency. The oscillator frequency can be lowered by adding an external capacitor to the OSC pin. Also, the OSC pin may be used to drive the LM2660 with an external clock up to 150 kHz. Through these methods, output ripple frequency and harmonics may be controlled.

Additionally, the LM2660 may be configured to divide a positive input voltage precisely in half. In this mode, input voltages as high as 11V may be used.

Basic Application Circuits

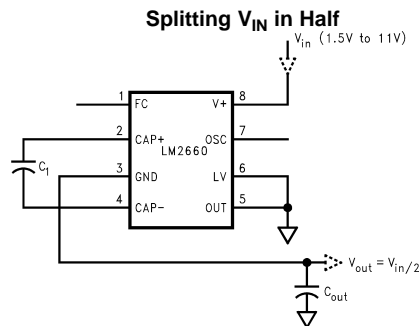
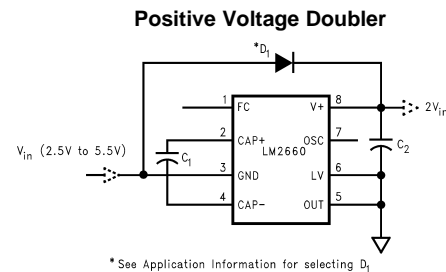
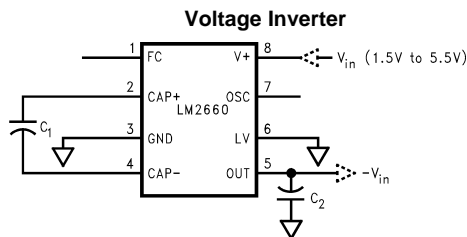

Please be aware that an important notice concerning availability, standard warranty, and use in critical applications of Texas Instruments semiconductor products and disclaimers thereto appears at the end of this data sheet.

All trademarks are the property of their respective owners.



These devices have limited built-in ESD protection. The leads should be shorted together or the device placed in conductive foam during storage or handling to prevent electrostatic damage to the MOS gates.

Absolute Maximum Ratings ⁽¹⁾⁽²⁾

Supply Voltage (V+ to GND, or GND to OUT)		6V	
LV		(OUT - 0.3V) to (GND + 3V)	
FC, OSC		The least negative of (OUT - 0.3V) or (V+ - 6V) to (V+ + 0.3V)	
V+ and OUT Continuous Output Current		120 mA	
Output Short-Circuit Duration to GND ⁽³⁾		1 sec.	
		Package	
		SOIC (D)	VSSOP (DGK)
Power Dissipation	(T _A = 25°C) ⁽⁴⁾	735 mW	500 mW
	T _J Max ⁽⁴⁾	150°C	150°C
	θ _{JA} ⁽⁴⁾	170°C/W	250°C/W
Operating Junction Temperature Range		-40°C to +85°C	
Storage Temperature Range		-65°C to +150°C	
Lead Temperature (Soldering, 10 seconds)		300°C	
ESD Rating		2 kV	

- (1) Absolute maximum ratings indicate limits beyond which damage to the device may occur. Electrical specifications do not apply when operating the device beyond its rated operating conditions.
- (2) If Military/Aerospace specified devices are required, please contact the Texas Instruments Sales Office/ Distributors for availability and specifications.
- (3) OUT may be shorted to GND for one second without damage. However, shorting OUT to V+ may damage the device and should be avoided. Also, for temperatures above 85°C, OUT must not be shorted to GND or V+, or device may be damaged.
- (4) The maximum allowable power dissipation is calculated by using $P_{DMax} = (T_{JMax} - T_A) / \theta_{JA}$, where T_{JMax} is the maximum junction temperature, T_A is the ambient temperature, and θ_{JA} is the junction-to-ambient thermal resistance of the specified package.

Electrical Characteristics

Limits in standard typeface are for $T_J = 25^\circ\text{C}$, and limits in **boldface** type apply over the full operating temperature range. Unless otherwise specified: $V_+ = 5\text{V}$, $\text{FC} = \text{Open}$, $C_1 = C_2 = 150\ \mu\text{F}$. ⁽¹⁾

Symbol	Parameter	Condition	Min	Typ	Max	Units	
V_+	Supply Voltage	$R_L = 1\text{k}$	Inverter, LV = Open	3.5		5.5	V
			Inverter, LV = GND	1.5		5.5	
			Doubler, LV = OUT	2.5		5.5	
I_Q	Supply Current	No Load	FC = Open		0.12	0.5	mA
		LV = Open	FC = V_+		1	3	
I_L	Output Current	$T_A \leq +85^\circ\text{C}$, $\text{OUT} \leq -4\text{V}$		100			mA
		$T_A > +85^\circ\text{C}$, $\text{OUT} \leq -3.8\text{V}$		100			
R_{OUT}	Output Resistance ⁽²⁾	$I_L = 100\ \text{mA}$	$T_A \leq +85^\circ\text{C}$		6.5	10	Ω
			$T_A > +85^\circ\text{C}$				
f_{OSC}	Oscillator Frequency	OSC = Open	FC = Open	5	10		kHz
			FC = V_+	40	80		
f_{SW}	Switching Frequency ⁽³⁾	OSC = Open	FC = Open	2.5	5		kHz
			FC = V_+	20	40		
I_{OSC}	OSC Input Current	FC = Open		± 2		μA	
		FC = V_+		± 16			
P_{EFF}	Power Efficiency	R_L (1k) between V_+ and OUT		96	98		%
		R_L (500) between GND and OUT		92	96		
		$I_L = 100\ \text{mA}$ to GND			88		
V_{OEFF}	Voltage Conversion Efficiency	No Load	99	99.96		%	

- (1) In the test circuit, capacitors C_1 and C_2 are 0.2 Ω maximum ESR capacitors. Capacitors with higher ESR will increase output resistance, reduce output voltage and efficiency.
- (2) Specified output resistance includes internal switch resistance and capacitor ESR.
- (3) The output switches operate at one half of the oscillator frequency, $f_{\text{OSC}} = 2f_{\text{SW}}$.

Test Circuits

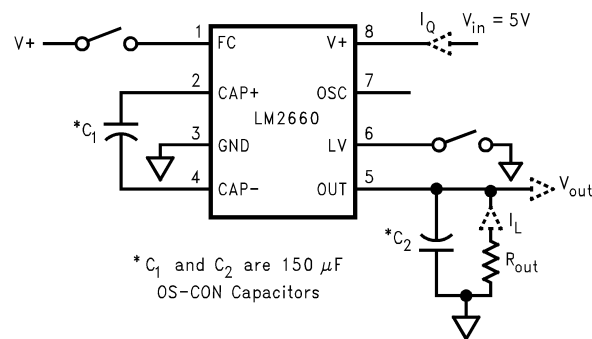

Figure 1. LM2660 Test Circuit

Typical Performance Characteristics

(Circuit of [Figure 1](#))

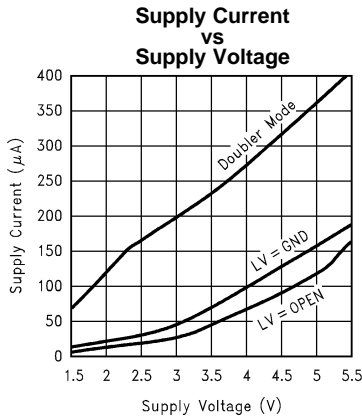

Figure 2.

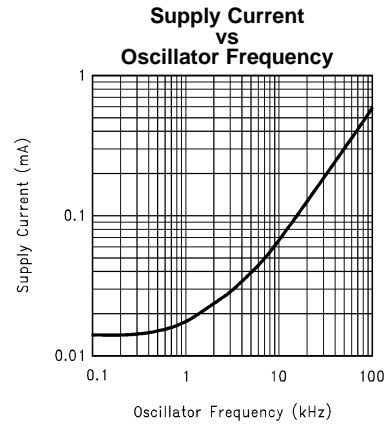

Figure 3.

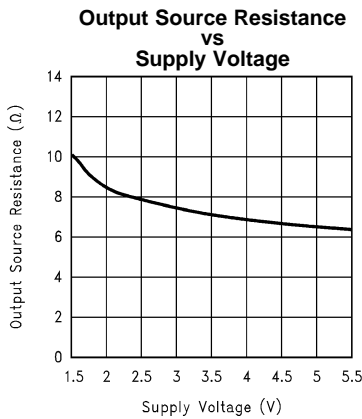

Figure 4.

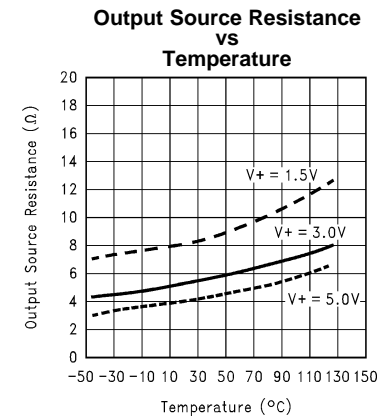

Figure 5.

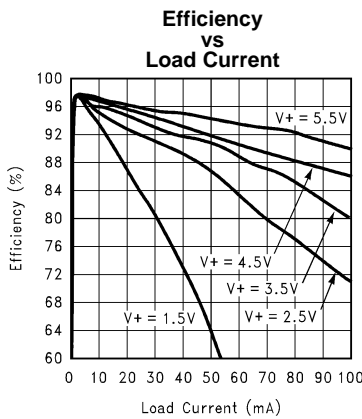

Figure 6.

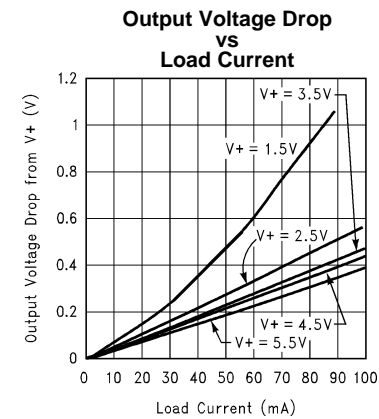

Figure 7.

Typical Performance Characteristics (continued)

(Circuit of Figure 1)

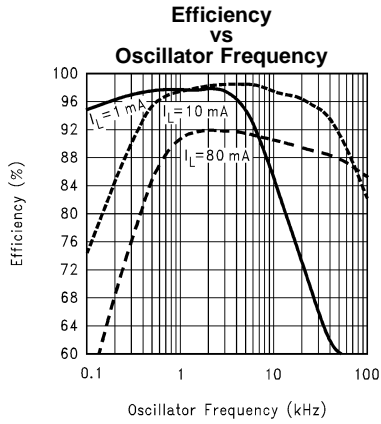

Figure 8.

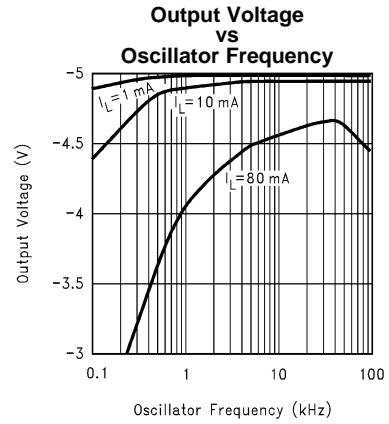

Figure 9.

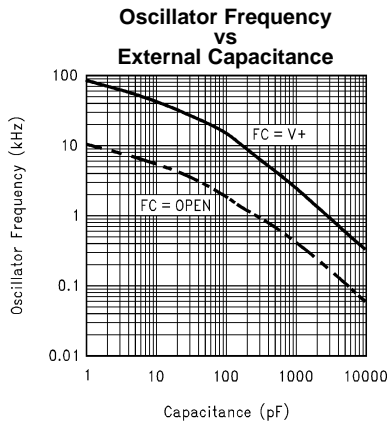

Figure 10.

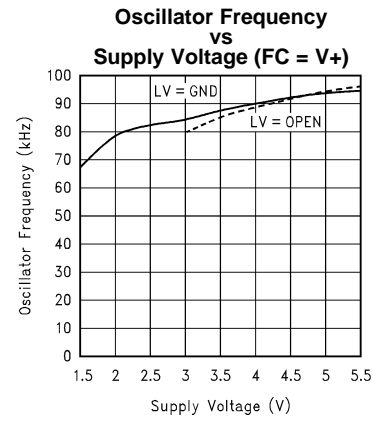

Figure 11.

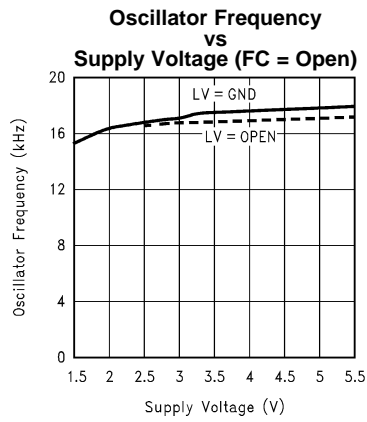

Figure 12.

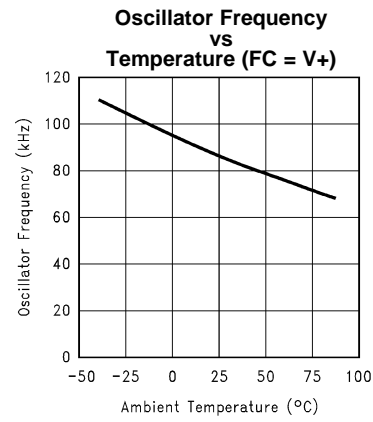

Figure 13.

Typical Performance Characteristics (continued)

(Circuit of Figure 1)

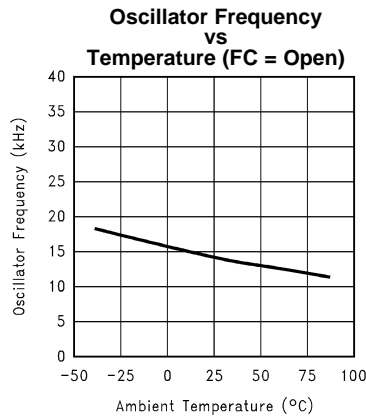

Figure 14.

CONNECTION DIAGRAMS

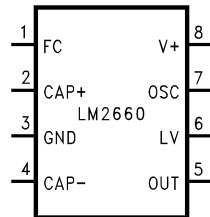

Figure 15. Top View 8-Lead SOIC (D) or VSSOP (DGK)

Pin Description

Pin	Name	Function	
		Voltage Inverter	Voltage Doubler
1	FC	Frequency control for internal oscillator:	Same as inverter.
		FC = open, $f_{OSC} = 10 \text{ kHz (typ)}$;	
		FC = V+, $f_{OSC} = 80 \text{ kHz (typ)}$;	
		FC has no effect when OSC pin is driven externally.	
2	CAP+	Connect this pin to the positive terminal of charge-pump capacitor.	Same as inverter.
3	GND	Power supply ground input.	Power supply positive voltage input.
4	CAP-	Connect this pin to the negative terminal of charge-pump capacitor.	Same as inverter.
5	OUT	Negative voltage output.	Power supply ground input.
6	LV	Low-voltage operation input. Tie LV to GND when input voltage is less than 3.5V. Above 3.5V, LV can be connected to GND or left open. When driving OSC with an external clock, LV must be connected to GND.	LV must be tied to OUT.
7	OSC	Oscillator control input. OSC is connected to an internal 15 pF capacitor. An external capacitor can be connected to slow the oscillator. Also, an external clock can be used to drive OSC.	Same as inverter except that OSC cannot be driven by an external clock.
8	V+	Power supply positive voltage input.	Positive voltage output.

Circuit Description

The LM2660 contains four large CMOS switches which are switched in a sequence to invert the input supply voltage. Energy transfer and storage are provided by external capacitors. Figure 16 illustrates the voltage conversion scheme. When S_1 and S_3 are closed, C_1 charges to the supply voltage $V+$. During this time interval switches S_2 and S_4 are open. In the second time interval, S_1 and S_3 are open and S_2 and S_4 are closed, C_1 is charging C_2 . After a number of cycles, the voltage across C_2 will be pumped to $V+$. Since the anode of C_2 is connected to ground, the output at the cathode of C_2 equals $-(V+)$ assuming no load on C_2 , no loss in the switches, and no ESR in the capacitors. In reality, the charge transfer efficiency depends on the switching frequency, the on-resistance of the switches, and the ESR of the capacitors.

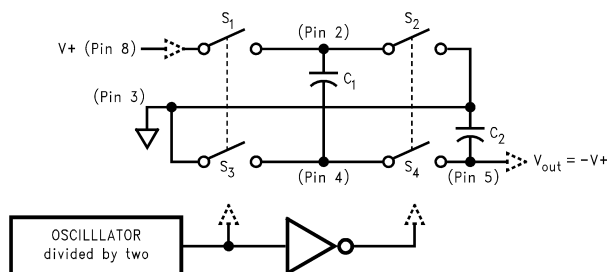

Figure 16. Voltage Inverting Principle

APPLICATION INFORMATION

SIMPLE NEGATIVE VOLTAGE CONVERTER

The main application of LM2660 is to generate a negative supply voltage. The voltage inverter circuit uses only two external capacitors as shown in the [Basic Application Circuits](#). The range of the input supply voltage is 1.5V to 5.5V. For a supply voltage less than 3.5V, the LV pin must be connected to ground to bypass the internal regulator circuitry. This gives the best performance in low voltage applications. If the supply voltage is greater than 3.5V, LV may be connected to ground or left open. The choice of leaving LV open simplifies the direct substitution of the LM2660 for the LMC7660 Switched Capacitor Voltage Converter.

The output characteristics of this circuit can be approximated by an ideal voltage source in series with a resistor. The voltage source equals $-(V_+)$. The output resistance R_{out} is a function of the ON resistance of the internal MOS switches, the oscillator frequency, and the capacitance and ESR of C_1 and C_2 . A good approximation is:

$$R_{out} \cong 2R_{SW} + \frac{2}{f_{osc} \times C_1} + 4ESR_{C1} + ESR_{C2} \quad (1)$$

where R_{SW} is the sum of the ON resistance of the internal MOS switches shown in [Figure 16](#).

High value, low ESR capacitors will reduce the output resistance. Instead of increasing the capacitance, the oscillator frequency can be increased to reduce the $2/(f_{osc} \times C_1)$ term. Once this term is trivial compared with R_{SW} and ESRs, further increasing in oscillator frequency and capacitance will become ineffective.

The peak-to-peak output voltage ripple is determined by the oscillator frequency, and the capacitance and ESR of the output capacitor C_2 :

$$V_{ripple} = \frac{I_L}{f_{osc} \times C_2} + 2 \times I_L \times ESR_{C2} \quad (2)$$

Again, using a low ESR capacitor will result in lower ripple.

POSITIVE VOLTAGE DOUBLER

The LM2660 can operate as a positive voltage doubler (as shown in the [Basic Application Circuits](#)). The doubling function is achieved by reversing some of the connections to the device. The input voltage is applied to the GND pin with an allowable voltage from 2.5V to 5.5V. The V_+ pin is used as the output. The LV pin and OUT pin must be connected to ground. The OSC pin can not be driven by an external clock in this operation mode. The unloaded output voltage is twice of the input voltage and is not reduced by the diode D_1 's forward drop.

The Schottky diode D_1 is only needed for start-up. The internal oscillator circuit uses the V_+ pin and the LV pin (connected to ground in the voltage doubler circuit) as its power rails. Voltage across V_+ and LV must be larger than 1.5V to insure the operation of the oscillator. During startup, D_1 is used to charge up the voltage at V_+ pin to start the oscillator; also, it protects the device from turning-on its own parasitic diode and potentially latching-up. Therefore, the Schottky diode D_1 should have enough current carrying capability to charge the output capacitor at start-up, as well as a low forward voltage to prevent the internal parasitic diode from turning-on. A Schottky diode like 1N5817 can be used for most applications. If the input voltage ramp is less than 10V/ms, a smaller Schottky diode like MBR0520LT1 can be used to reduce the circuit size.

SPLIT V_+ IN HALF

Another interesting application shown in the [Basic Application Circuits](#) is using the LM2660 as a precision voltage divider. Since the off-voltage across each switch equals $V_{IN}/2$, the input voltage can be raised to +11V.

CHANGING OSCILLATOR FREQUENCY

The internal oscillator frequency can be selected using the Frequency Control (FC) pin. When FC is open, the oscillator frequency is 10 kHz; when FC is connected to V_+ , the frequency increases to 80 kHz. A higher oscillator frequency allows smaller capacitors to be used for equivalent output resistance and ripple, but increases the typical supply current from 0.12 mA to 1 mA.

The oscillator frequency can be lowered by adding an external capacitor between OSC and GND. (See [Typical Performance Characteristics](#).) Also, in the inverter mode, an external clock that swings within 100 mV of V_+ and GND can be used to drive OSC. Any CMOS logic gate is suitable for driving OSC. LV must be grounded when driving OSC. The maximum external clock frequency is limited to 150 kHz.

The switching frequency of the converter (also called the charge pump frequency) is half of the oscillator frequency.

NOTE

OSC cannot be driven by an external clock in the voltage-doubling mode.

Table 1. LM2660 Oscillator Frequency Selection

FC	OSC	Oscillator
Open	Open	10 kHz
V+	Open	80 kHz
Open or V+	External Capacitor	See Typical Performance Characteristics
N/A	External Clock	External Clock
	(inverter mode only)	Frequency

CAPACITOR SELECTION

As discussed in the [SIMPLE NEGATIVE VOLTAGE CONVERTER](#) section, the output resistance and ripple voltage are dependent on the capacitance and ESR values of the external capacitors. The output voltage drop is the load current times the output resistance, and the power efficiency is

$$\eta = \frac{P_{out}}{P_{in}} = \frac{I_L^2 R_L}{I_L^2 R_L + I_L^2 R_{out} + I_Q(V+)} \quad (3)$$

Where $I_Q(V+)$ is the quiescent power loss of the IC device, and $I_L^2 R_{OUT}$ is the conversion loss associated with the switch on-resistance, the two external capacitors and their ESRs.

Since the switching current charging and discharging C_1 is approximately twice as the output current, the effect of the ESR of the pumping capacitor C_1 is multiplied by four in the output resistance. The output capacitor C_2 is charging and discharging at a current approximately equal to the output current, therefore, its ESR only counts once in the output resistance. However, the ESR of C_2 directly affects the output voltage ripple. Therefore, low ESR capacitors ([Table 2](#)) are recommended for both capacitors to maximize efficiency, reduce the output voltage drop and voltage ripple. For convenience, C_1 and C_2 are usually chosen to be the same.

The output resistance varies with the oscillator frequency and the capacitors. In [Figure 17](#), the output resistance vs. oscillator frequency curves are drawn for three different tantalum capacitors. At very low frequency range, capacitance plays the most important role in determining the output resistance. Once the frequency is increased to some point (such as 20 kHz for the 150 μ F capacitors), the output resistance is dominated by the ON resistance of the internal switches and the ESRs of the external capacitors. A low value, smaller size capacitor usually has a higher ESR compared with a bigger size capacitor of the same type. For lower ESR, use ceramic capacitors.

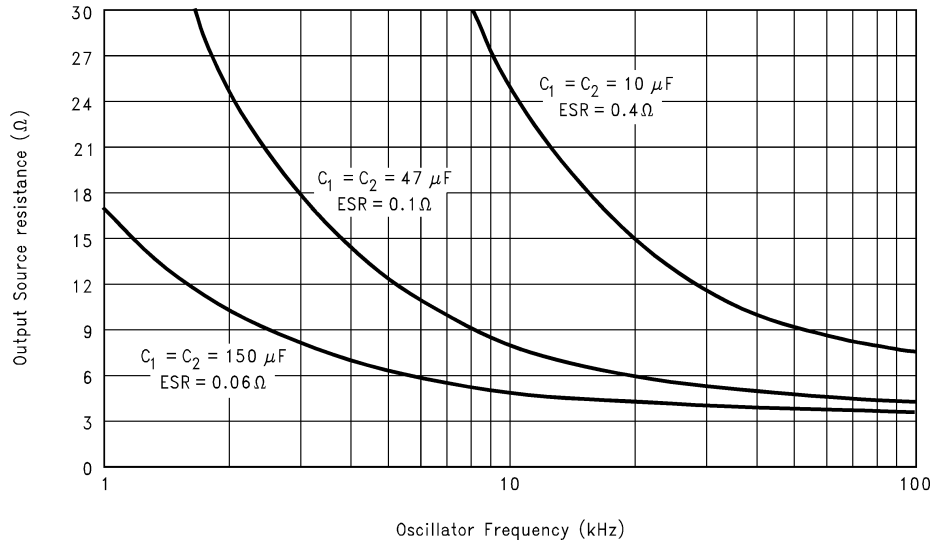

Figure 17. Output Source Resistance vs Oscillator Frequency

Table 2. Low ESR Capacitor Manufacturers

Manufacturer	Capacitor Type
Nichicon Corp.	PL, PF series, through-hole aluminum electrolytic
AVX Corp.	TPS series, surface-mount tantalum
Sprague	593D, 594D, 595D series, surface-mount tantalum
Sanyo	OS-CON series, through-hole aluminum electrolytic

Other Applications

PARALLELING DEVICES

Any number of LM2660s can be paralleled to reduce the output resistance. Each device must have its own pumping capacitor C_1 , while only one output capacitor C_{out} is needed as shown in Figure 18. The composite output resistance is:

$$R_{out} = \frac{R_{out \text{ of each LM2660}}}{\text{Number of Devices}} \tag{4}$$

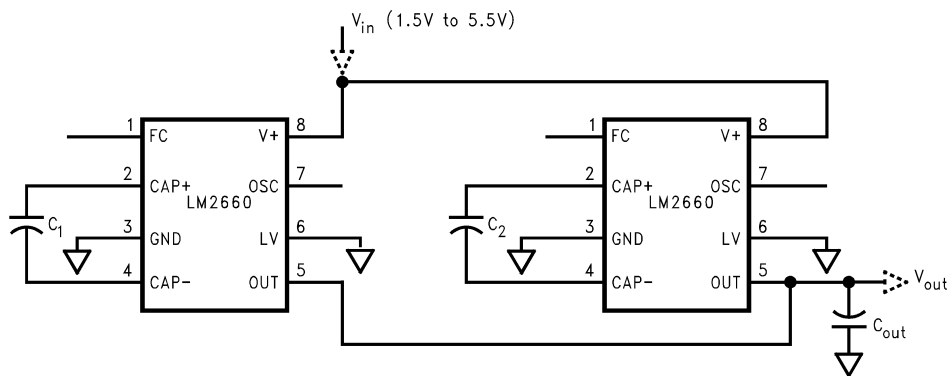

Figure 18. Lowering Output Resistance by Paralleling Devices

CASCADING DEVICES

Cascading the LM2660s is an easy way to produce a greater negative voltage (as shown in Figure 19). If n is the integer representing the number of devices cascaded, the unloaded output voltage V_{out} is $(-nV_{in})$. The effective output resistance is equal to the weighted sum of each individual device:

$$R_{out} = nR_{out_1} + \frac{n}{2}R_{out_2} + \dots + R_{out_n} \quad (5)$$

A three-stage cascade circuit shown in Figure 20 generates $-3V_{in}$ from V_{in} .

Cascading is also possible when devices are operating in doubling mode. In Figure 21, two devices are cascaded to generate $3V_{in}$.

An example of using the circuit in Figure 20 or Figure 21 is generating +15V or -15V from a +5V input.

Note that, the number of n is practically limited since the increasing of n significantly reduces the efficiency and increases the output resistance and output voltage ripple.

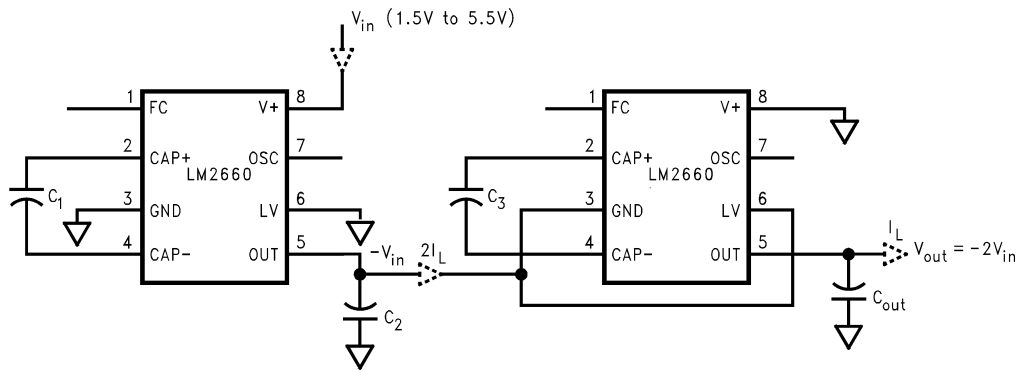

Figure 19. Increasing Output Voltage by Cascading Devices

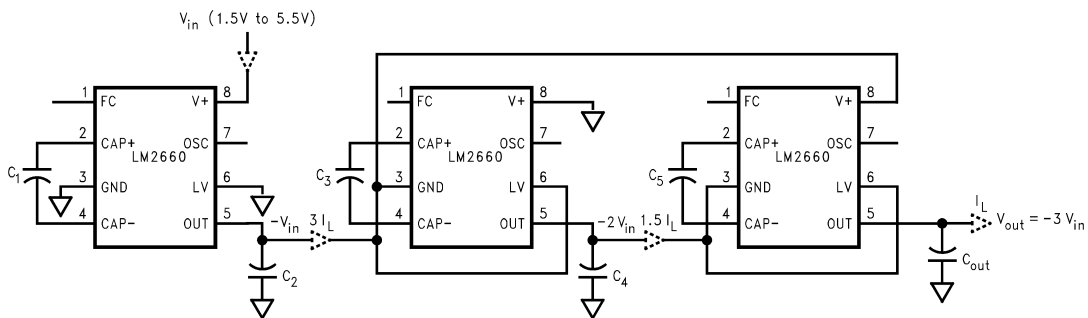

Figure 20. Generating $-3V_{in}$ from $+V_{in}$

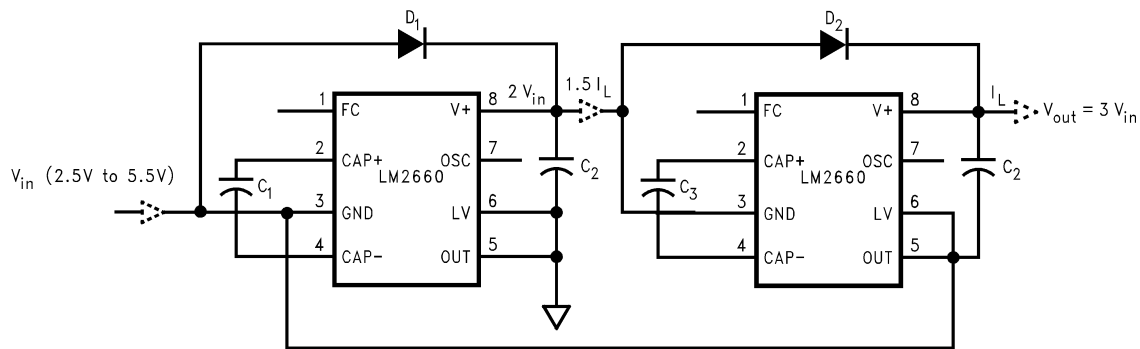

Figure 21. Generating $+3V_{in}$ from $+V_{in}$

REVISION HISTORY

Changes from Revision C (May 2013) to Revision D	Page
<hr/> <ul style="list-style-type: none">• Changed layout of National Data Sheet to TI format	<hr/> 12

PACKAGING INFORMATION

Orderable Device	Status (1)	Package Type	Package Drawing	Pins	Package Qty	Eco Plan (2)	Lead/Ball Finish	MSL Peak Temp (3)	Op Temp (°C)	Top-Side Markings (4)	Samples
LM2660M	ACTIVE	SOIC	D	8	95	TBD	Call TI	Call TI	-40 to 85	LM26 60M	Samples
LM2660M/NOPB	ACTIVE	SOIC	D	8	95	Green (RoHS & no Sb/Br)	CU SN	Level-1-260C-UNLIM	-40 to 85	LM26 60M	Samples
LM2660MM	ACTIVE	VSSOP	DGK	8	1000	TBD	Call TI	Call TI	-40 to 85	S01A	Samples
LM2660MM/NOPB	ACTIVE	VSSOP	DGK	8	1000	Green (RoHS & no Sb/Br)	CU SN	Level-1-260C-UNLIM	-40 to 85	S01A	Samples
LM2660MX	ACTIVE	SOIC	D	8	2500	TBD	Call TI	Call TI	-40 to 85	LM26 60M	Samples
LM2660MX/NOPB	ACTIVE	SOIC	D	8	2500	Green (RoHS & no Sb/Br)	CU SN	Level-1-260C-UNLIM	-40 to 85	LM26 60M	Samples

(1) The marketing status values are defined as follows:

ACTIVE: Product device recommended for new designs.

LIFEBUY: TI has announced that the device will be discontinued, and a lifetime-buy period is in effect.

NRND: Not recommended for new designs. Device is in production to support existing customers, but TI does not recommend using this part in a new design.

PREVIEW: Device has been announced but is not in production. Samples may or may not be available.

OBSOLETE: TI has discontinued the production of the device.

(2) Eco Plan - The planned eco-friendly classification: Pb-Free (RoHS), Pb-Free (RoHS Exempt), or Green (RoHS & no Sb/Br) - please check <http://www.ti.com/productcontent> for the latest availability information and additional product content details.

TBD: The Pb-Free/Green conversion plan has not been defined.

Pb-Free (RoHS): TI's terms "Lead-Free" or "Pb-Free" mean semiconductor products that are compatible with the current RoHS requirements for all 6 substances, including the requirement that lead not exceed 0.1% by weight in homogeneous materials. Where designed to be soldered at high temperatures, TI Pb-Free products are suitable for use in specified lead-free processes.

Pb-Free (RoHS Exempt): This component has a RoHS exemption for either 1) lead-based flip-chip solder bumps used between the die and package, or 2) lead-based die adhesive used between the die and leadframe. The component is otherwise considered Pb-Free (RoHS compatible) as defined above.

Green (RoHS & no Sb/Br): TI defines "Green" to mean Pb-Free (RoHS compatible), and free of Bromine (Br) and Antimony (Sb) based flame retardants (Br or Sb do not exceed 0.1% by weight in homogeneous material)

(3) MSL, Peak Temp. -- The Moisture Sensitivity Level rating according to the JEDEC industry standard classifications, and peak solder temperature.

(4) Multiple Top-Side Markings will be inside parentheses. Only one Top-Side Marking contained in parentheses and separated by a "~" will appear on a device. If a line is indented then it is a continuation of the previous line and the two combined represent the entire Top-Side Marking for that device.

Important Information and Disclaimer: The information provided on this page represents TI's knowledge and belief as of the date that it is provided. TI bases its knowledge and belief on information provided by third parties, and makes no representation or warranty as to the accuracy of such information. Efforts are underway to better integrate information from third parties. TI has taken and

continues to take reasonable steps to provide representative and accurate information but may not have conducted destructive testing or chemical analysis on incoming materials and chemicals. TI and TI suppliers consider certain information to be proprietary, and thus CAS numbers and other limited information may not be available for release.

In no event shall TI's liability arising out of such information exceed the total purchase price of the TI part(s) at issue in this document sold by TI to Customer on an annual basis.

IMPORTANT NOTICE

Texas Instruments Incorporated and its subsidiaries (TI) reserve the right to make corrections, enhancements, improvements and other changes to its semiconductor products and services per JESD46, latest issue, and to discontinue any product or service per JESD48, latest issue. Buyers should obtain the latest relevant information before placing orders and should verify that such information is current and complete. All semiconductor products (also referred to herein as "components") are sold subject to TI's terms and conditions of sale supplied at the time of order acknowledgment.

TI warrants performance of its components to the specifications applicable at the time of sale, in accordance with the warranty in TI's terms and conditions of sale of semiconductor products. Testing and other quality control techniques are used to the extent TI deems necessary to support this warranty. Except where mandated by applicable law, testing of all parameters of each component is not necessarily performed.

TI assumes no liability for applications assistance or the design of Buyers' products. Buyers are responsible for their products and applications using TI components. To minimize the risks associated with Buyers' products and applications, Buyers should provide adequate design and operating safeguards.

TI does not warrant or represent that any license, either express or implied, is granted under any patent right, copyright, mask work right, or other intellectual property right relating to any combination, machine, or process in which TI components or services are used. Information published by TI regarding third-party products or services does not constitute a license to use such products or services or a warranty or endorsement thereof. Use of such information may require a license from a third party under the patents or other intellectual property of the third party, or a license from TI under the patents or other intellectual property of TI.

Reproduction of significant portions of TI information in TI data books or data sheets is permissible only if reproduction is without alteration and is accompanied by all associated warranties, conditions, limitations, and notices. TI is not responsible or liable for such altered documentation. Information of third parties may be subject to additional restrictions.

Resale of TI components or services with statements different from or beyond the parameters stated by TI for that component or service voids all express and any implied warranties for the associated TI component or service and is an unfair and deceptive business practice. TI is not responsible or liable for any such statements.

Buyer acknowledges and agrees that it is solely responsible for compliance with all legal, regulatory and safety-related requirements concerning its products, and any use of TI components in its applications, notwithstanding any applications-related information or support that may be provided by TI. Buyer represents and agrees that it has all the necessary expertise to create and implement safeguards which anticipate dangerous consequences of failures, monitor failures and their consequences, lessen the likelihood of failures that might cause harm and take appropriate remedial actions. Buyer will fully indemnify TI and its representatives against any damages arising out of the use of any TI components in safety-critical applications.

In some cases, TI components may be promoted specifically to facilitate safety-related applications. With such components, TI's goal is to help enable customers to design and create their own end-product solutions that meet applicable functional safety standards and requirements. Nonetheless, such components are subject to these terms.

No TI components are authorized for use in FDA Class III (or similar life-critical medical equipment) unless authorized officers of the parties have executed a special agreement specifically governing such use.

Only those TI components which TI has specifically designated as military grade or "enhanced plastic" are designed and intended for use in military/aerospace applications or environments. Buyer acknowledges and agrees that any military or aerospace use of TI components which have **not** been so designated is solely at the Buyer's risk, and that Buyer is solely responsible for compliance with all legal and regulatory requirements in connection with such use.

TI has specifically designated certain components as meeting ISO/TS16949 requirements, mainly for automotive use. In any case of use of non-designated products, TI will not be responsible for any failure to meet ISO/TS16949.

Products

Audio	www.ti.com/audio
Amplifiers	amplifier.ti.com
Data Converters	dataconverter.ti.com
DLP® Products	www.dlp.com
DSP	dsp.ti.com
Clocks and Timers	www.ti.com/clocks
Interface	interface.ti.com
Logic	logic.ti.com
Power Mgmt	power.ti.com
Microcontrollers	microcontroller.ti.com
RFID	www.ti-rfid.com
OMAP Applications Processors	www.ti.com/omap
Wireless Connectivity	www.ti.com/wirelessconnectivity

Applications

Automotive and Transportation	www.ti.com/automotive
Communications and Telecom	www.ti.com/communications
Computers and Peripherals	www.ti.com/computers
Consumer Electronics	www.ti.com/consumer-apps
Energy and Lighting	www.ti.com/energy
Industrial	www.ti.com/industrial
Medical	www.ti.com/medical
Security	www.ti.com/security
Space, Avionics and Defense	www.ti.com/space-avionics-defense
Video and Imaging	www.ti.com/video

TI E2E Community

e2e.ti.com